

Handicap Accessible Planting Boxes Grant Matheke

If you are concerned about the wood rotting with the use of *all weather wood*, you may substitute *ground contact wood*. However, there may be some leaching of preservatives with *ground contact wood*.

After constructing the top section, attach it to the bottom section with grabber screws. Drill holes at one-foot intervals in the bottom plywood. Then fill with container gardening soil.

Commercial soil mixes can be used but are expensive. Recipes for suitable soil mixes can be found in the Alaska Cooperative Extension publication 8GA-0037, 'Window Boxes' or in books on container gardening.

The addition of a water absorbing polymer such as Terra-Sorb™ or SuperSorb® will increase the water holding capacity and porosity of your planting media. This allows for less frequent watering of your planters.



Figure 1. Handicap accessible raised planting beds can be appealing structures in your garden.

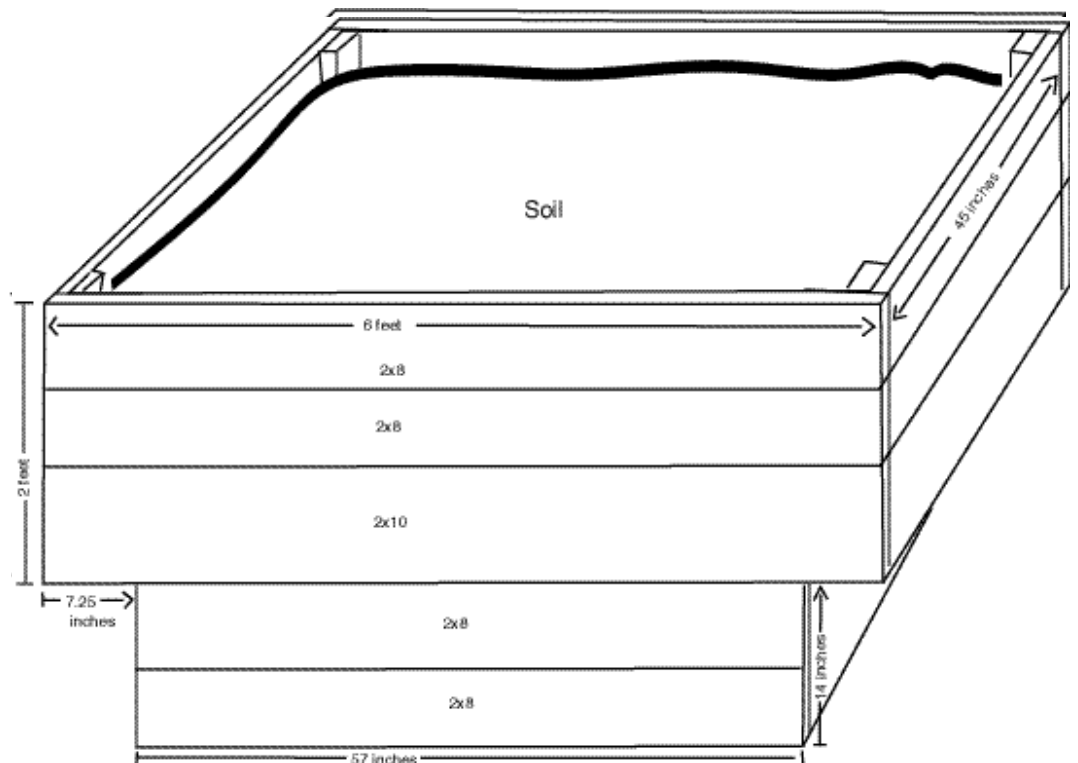

Figure 1. 3D view of tall planter. To construct a shorter version for wheelchair accessibility, eliminate the upper 2x8 row on the top section.

Table 1. Interior dimensions and volume of planter boxes.

	Width (ft)	Length (ft)	Depth (ft)	Volume (ft ³)
Tall Planter	3.67	5.67	1.5	31
Short Planter	3.67	5.67	0.92	19

Table 2. Materials list for handicap accessible planters.

1 box 3" grabber guard screws

Bottom section of both planters:

4 2" x 8" x 4'9 1/2" long side

4 2" x 8" x 4'9 1/2" short side

4 2" x 4" x 14" corner braces

Top section short planter:

2 2" x 10" x 6' long side

2 2" x 8" x 6' long side

2 2" x 10" x 4' short side

2 2" x 8" x 4' short side

3 2" x 4" x 13" corner braces

7 2" x 4" x 69" bottom supports

4' x 69" 3/4" marine or exterior plywood

Top section for tall planter:

2 2" x 10" x 6' long side

4 2" x 8" x 6' long side

2 2" x 10" x 4' short side

4 2" x 8" x 4' short side

4 2" x 4" x 20.5" corner braces

7 2" x 4" x 69" bottom supports

4' x 69" 3/4" marine or exterior plywood

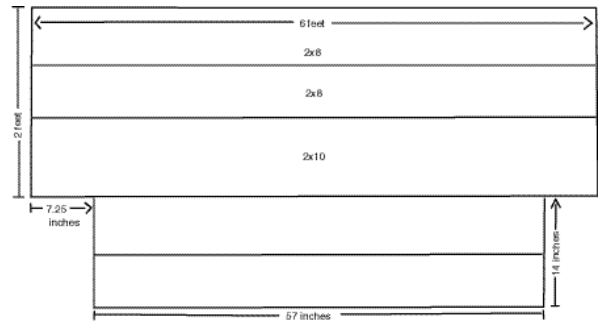

Figure 2. Side view of tall planter.

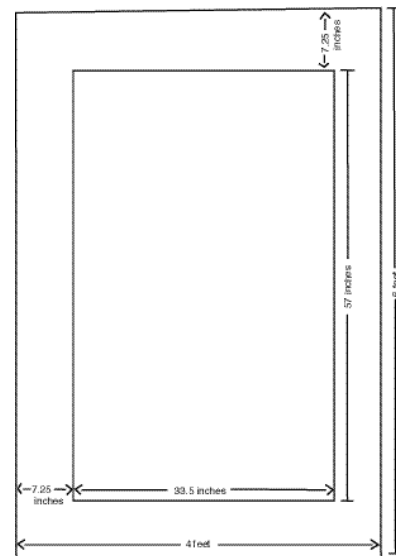

Figure 3. Top view of planters.

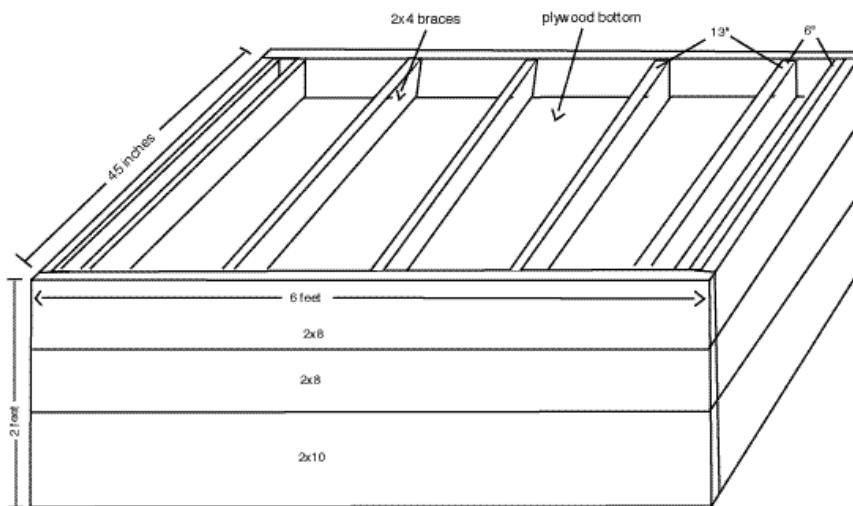

Figure 4. Top section of planter shown upside down to view construction. The first 2x4 brace is placed directly against the outside piece. The second bottom brace on either side is in 6 inches, then the remaining three braces are 13 inches apart. Drill holes at one-foot intervals before turning over.

The University of Alaska Fairbanks is accredited by the Commission on Colleges of the Northwest Association of Schools and Colleges. UAF is an AA/EQ employer and educational institution.

Material appearing herein may be reprinted provided no endorsement of a commercial product is stated or implied. Please credit the researchers involved and the Agricultural and Forestry Experiment Station, School of Agriculture and Resources Management, University of Alaska Fairbanks.

