

WASTE-MANAGEMENT SYSTEMS FOR DAIRY FARMS IN ALASKA

Robert F. Cullum

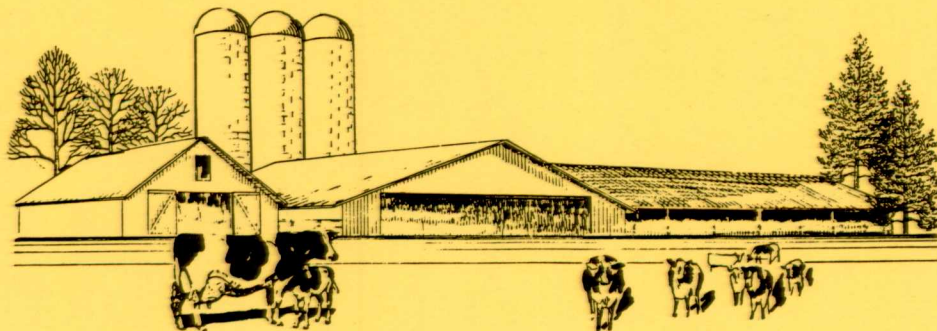

Agricultural Experiment Station
School of Agriculture and Land Resources Management
University of Alaska

James V. Drew, Director

Circular 47

May 1983

UNIVERSITY OF ALASKA

Dr. Jay Barton President
Dr. Patrick J. O'Rourke Chancellor, University of Alaska, Fairbanks
Dr. William G. Phillips Vice Chancellor for Academic Affairs
Dr. Keith B. Mather Vice Chancellor for Research and Advanced Study
Dr. James V. Drew Dean, School of Agriculture and Land Resources
Management, and Director, Agricultural Experiment Station

BOARD OF REGENTS

Donald B. Abel, Jr., President
John Shively, Vice President
Ann Parrish, Secretary
Herbert C. Lang, Treasurer
Hugh B. Fate, Jr., D.M.D., Past President
Edward B. Rasmuson, Past President
Ruth Burnett
Gordon Evans
Sara T. Hannan
Roy Huhndorf
Thomas J. Miklautsch

The Agricultural Experiment Station at the University of Alaska provides station publications and equal educational and employment opportunities to all, regardless of race, color, religion, national origin, sex, age, disability, or status as a Vietnam era or disabled veteran.

In order to simplify terminology, trade names of products or equipment may have been used in this publication. No endorsement of products or firms mentioned is intended, nor is criticism implied of those not mentioned.

Material appearing herein may be reprinted provided no endorsement of a commercial product is stated or implied. Please credit the researchers involved and the Agricultural Experiment Station, University of Alaska.

Circular (University of Alaska, Fairbanks, Agricultural
Experiment Station)
"Circular"

WASTE-MANAGEMENT SYSTEMS

FOR

DAIRY FARMS IN ALASKA

Robert F. Cullum
Assistant Professor of Agricultural Engineering

Agricultural Experiment Station
School of Agriculture and Land Resources Management
University of Alaska
James V. Drew, Director

Circular 47
ALASKA
S
33
E22
no. 47

May 1983

RASMUSON LIBRARY
UNIVERSITY OF ALASKA-FAIRBANKS

TABLE OF CONTENTS

Introduction	1
Liquid-Manure Systems	3
Semisolid-Manure Systems	23
Conclusions	29
Bibliography	31

List of Figures

Figure 1. Major features of the pneumatic manure-transfer system.	7
Figure 2. Hollow-piston transfer pump.	8
Figure 3. Solid-piston transfer pump.	9
Figure 4. Gravity-flow, transfer, storage, and load-out system.	11
Figure 5. A typical outside, earthen-basin, liquid-manure storage with proper chained-link fence.	12
Figure 6. Open-pit pump provides convenience and fastest agitation or pumping from earthen basins.	14
Figure 7. Earthen basin with pumping dock that allows a vertical-shaft manure pump to agitate and pump the liquid material into the tankwagon.	15
Figure 8. Side-mounted, adjustable, spring-loaded knives inject manure into the soil from the tankwagon.	16
Figure 9. The traveling gun-irrigation system consists of an open-pit manure pump, aluminum pipe, flexible pipe, and the traveling nozzle.	18

Figure 10. The two-hose method consists of a feeder hose coupled to the drag hose which is in turn coupled to the spring-loaded injector shanks. The injection system is attached to the tractor which pulls the drag hose as manure is pumped from the storage facility.	19
Figure 11. Above-ground, liquid-manure, storage system setup in typical dairy operation.	21
Figure 12. A picket-drained storage system which is loaded along the middle of a long side.	24
Figure 13. An above-ground roofed structure for semisolid-manure storage.	26

INTRODUCTION

Manure handling is one of the most unappreciated chores associated with livestock enterprises. It is also the most difficult problem to solve in a totally satisfactory manner because physical characteristics of manure usually change with the daily weather, seasons, and ration. All handling systems have their limitations, and none works perfectly all the time. The problem of manure handling is most easily solved if cows are confined in covered housing because physical characteristics of the manure remain more uniform under cover — no surface water, less drying and freezing. Improper design of manure-handling systems may lead to higher costs for redesign than new facilities would cost. Even with new facilities, manure handling may present major problems if systems are inadequate for the particular environmental conditions of the area.

In continuing efforts to improve livestock waste-handling systems, new methods and equipment are being used. Waste-system components, related closely to dairy-manure handling, deal with removal of waste from buildings and storage facilities that are separated from the livestock housing facility. The major systems provide for collection, transfer, storage, and land application, and are divided into two groups — liquid and semisolid manure-handling systems.

Many manure-handling systems are used in the United States. Not all of these systems, however, are adapted to northern climates. The Alaska Department of Environmental Conservation currently has no code of practice for livestock waste facilities. The agency, however, must be notified for approval of waste-treatment systems used in livestock enterprises. The systems described in this report comply with current state codes in the northern United States and Canada, and most are adaptable to the environmental conditions of Alaska.

LIQUID-MANURE SYSTEMS

Transfer Systems

Recent developments of pneumatic conveying systems and large piston-type transfer pumps coupled with a tractor scraper, mechanical scraper, or hydraulic (flush) system for moving manure from barns to outside storage facilities have made outdoor systems popular for storage of liquid manure (less than 12 percent solids). Outdoor facilities are used to extend the storage capacity of existing under-barn tanks or to meet total storage needs in livestock enterprises. The systems best adapted to northern conditions for outdoor storage of liquid manure are earthen basins, above-ground storage, and pits.

Hydraulic Transport: Hydraulic removal of manure using relatively large quantities of water has been used in the southeast, southwest, and west coast of the 48 conterminous states for several years for flushing milk parlors, cow-holding areas, and paved feed alleys associated with open lots. In the past 5 to 6 years, midwestern dairymen have built free-stall barns with sloped (3 to 5 percent) alleys that can be flushed. Operation of a free-stall flush system commenced at the Agricultural Experiment Station's Matanuska Farm in 1972. About the same time, a modified-flush system with slatted floors and a lagoon was constructed at Hamilton Farms just outside of Palmer.

Flush barns can be designed to provide nearly complete manure removal from alley floors, but the manure most difficult to remove is deposited against curbs behind free stalls. The alleys must either be perfectly flat from curb to curb or have a slight crown in the center, 1 to 1.5 cm (0.4 to 0.6 in) high, to keep the flow of the flushing water forced toward the curbs. It is essential the elevations at the curbs of the alley floor at any given point in the barn be equal. Curbs along flushed alleys generally should have a height of about 25 cm (10 in). Alleys across rows of stalls should be elevated so that curbs along flush alleys are continuous. If curbs are stopped

for cross alleys, flush water can spread into the cross alley, thus losing the energy needed for efficient flushing.

Typically, the flushing process is initiated by a sudden release of water from a tank. Sealed gates are available commercially for installation in tanks built on-site and include a sealed, front-drop gate; a lift, or sluice, gate that forms an opening through which water is released; and gates with circular openings which are closed by a tire arrangement seated against the openings. Trapezoidal steel tanks that pivot on their supports in order to dump water automatically when they become full have been used. Tanks utilizing the siphon technique also have been successfully developed to release water automatically.

There is some concern regarding the performance of flush systems in barns in northern climates during subfreezing weather. Experiences in Michigan and Minnesota have shown that in naturally ventilated (cold), free-stall barns, the flush system is generally not used for one to two months during midwinter. However, the flush system is used in some cold barns all winter. Such use seems to be related to the location of the flush tanks and pickup channels that collect the flushed material at the lower end of the barn. If both flush tanks and pickup channels are inside the barn, flushing is possible all winter. Where either or both of these devices are located outside of the barn, dairymen generally do not flush when outside temperatures stay below -7 to -4°C (19 to 25°F). Freezing problems generally occur first around the tanks and the pickup channels rather than on the alley floors. The floors seem to drain until freezing begins to occur in areas in which flushing velocities are low, such as near the pickup channel or in the trailing portion of the flow leaving the flush tanks.

Barns located in northern climates present another potential problem: disease associated with humidity and ventilation of mechanically ventilated buildings. High moisture levels result in these installations, and proper ventilation is a necessity. Diseases in dairy herds may be transmitted through the water used in flush more readily in buildings in which ventilation is inadequate.

Flush systems can also be a cause of increased foot problems in cattle. Protrusions in the concrete floor remain sharp because floors are never scraped and are washed clean when flushed. Manure is not permitted to

build up around the protrusions to decrease their height of roughness and cushion their sharpness. It is extremely important that the floors be finished with only the degree of roughness necessary to provide safe footing for the cattle. A rough broom finish has been used successfully in flush barns that are scraped occasionally.

Liquid-Solid Separation: Some waste-handling systems can be managed more easily if a liquid-solid separation process is included as part of the system. Possibly the biggest problem associated with flush systems is disposal of the diluted manure once it leaves the barn. Generally, flushed material is stored in an earthen basin and then pumped periodically through irrigation equipment for land application. Solids settle near the entry point, and, in large basins, agitation and resuspension of these solids is difficult. The use of some type of liquid-solid separation device is recommended for partial removal, of the solids before the liquid goes into the basin.

Separation processes remove coarse solids from liquid manure, leaving an easily pumpable liquid containing the fine solids and most of the nutrients. If liquids and solids were separated, water could be recycled from the basin and reused for flushing, particularly if the barn were flushed when the cows are in the holding area for milking instead of in the alleys. The most prominent methods and equipment available include flow over stationary screens, vibrating screens, roller-squeezer devices, and settling basins with mechanical solids removal.

A stationary screen allows liquid from the diluted manure to pass through the holes as solids are washed down the screen. The only mechanical device required is the pump, which is generally needed to move the diluted manure onto the screen.

Vibrating screens have been used extensively in warm climates to remove the coarse solids from the diluted manure. The coarse solids can then be dried and used as bedding. These screens also require a pump to lift diluted manure and discharge it on the elevated screen. The vibrating screens however, have required a considerable maintenance when used for livestock waste.

Several machines of the roller-squeezer type are available for use with livestock waste and are recommended for diluted manure. The material goes through a series of pairs of rollers having successively higher pressures to

squeeze the liquid from the solids. The solids are reduced to 65 to 75 percent moisture and can be dried for use as bedding or feed.

Settling basins work best for manure diluted to several times the original volume. Dilution seems to separate the fines from the coarse solids, thus promoting a relatively complete separation as the solids settle. In warm climates, a gutter cleaner and an inclined elevator section have been used to remove settled solids from the bottom of a settling basin and to promote some liquid drainage from those solids that are slowly conveyed up the elevator. Freezing, however, becomes a problem if the basin is unprotected. A length-to-depth ratio of 6:1 or greater, and a length-to-width ratio of 3:1 or more are recommended. These solids are suitable for bedding after additional drying.

Air-Pressure, Manure-Transfer System: Air-operated, manure-moving systems (Figure 1) consist of a large tank to receive manure and a supply of compressed air to force the manure out of the tank through a large underground pipeline [30.5 cm (12 in)]. Manure from a gutter cleaner or tractor scraper is dropped into a large, specially designed and constructed, underground steel holding tank [5677L (1500 gal)]. The tank has an outlet at the bottom with a flap-type, antiback-flow valve coupled with the 30.5 cm (12 in) polyvinyl chloride (PVC, high-density polyethylene [HDPE] recommended in extremely cold regions) pipe leading to the outdoor manure-storage basin. An air-powered cylinder seals the loading hatch with compressed air fed through the top of the tank. As pressure increases in the tank, manure is forced through the bottom pipe to storage. Manure in a 2.1-m (7.0-ft) diameter tank at a pressure of 0.70 kg/cm^2 (10 psi) would have a force of 25,170 kg (55,420 lb) pushing on it. While these units are usually rated up to 4.2 kg/cm^2 (60 psi), it is easy to see why they normally operate at low to moderate air pressure of less than 0.70 kg/cm^2 (10 psi).

As the tank is evacuated, the surface of the manure-storage basin is penetrated by air and has the appearance of a bubbling volcano while the excess air is released from the system. This system does disturb the basin's crust, however, no noticeable increase in odor from the storage facility results. If dry manure or manure containing much bedding is added to the tank, dairymen most generally add extra water to be sure the manure slips

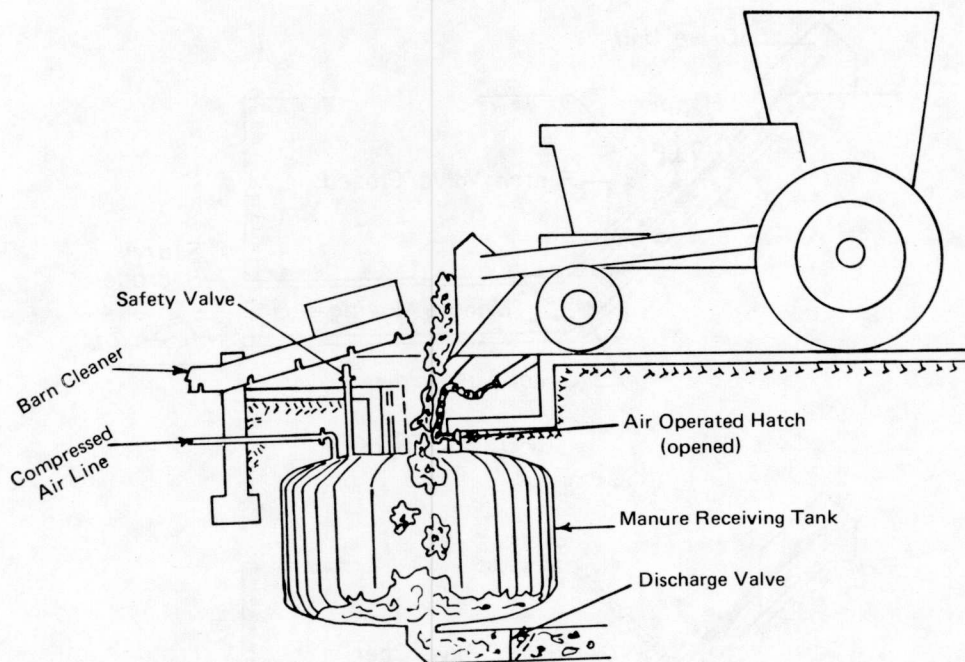

Figure 1. Major features of the pneumatic manure transfer system (Graves, 1977).

through the pipe adequately. Therefore, pneumatic transfer should be considered a liquid-handling system even though some commercial literature shows the pneumatic conveying system being used with semisolid manure storage.

Piston Transfer Pumps: Large, slow-speed, piston pumps are used widely for transfer of manure from barns to outdoor storage facilities. Two general types are available: the hollow-piston (Figure 2) and the solid-piston (Figure 3). The hollow-piston pump is usually used with liquid-manure systems, since additional water may be needed to move dry manure through the piston. The solid-piston pumps are used with solid and semisolid systems since dryer, more heavily bedded manure can be handled.

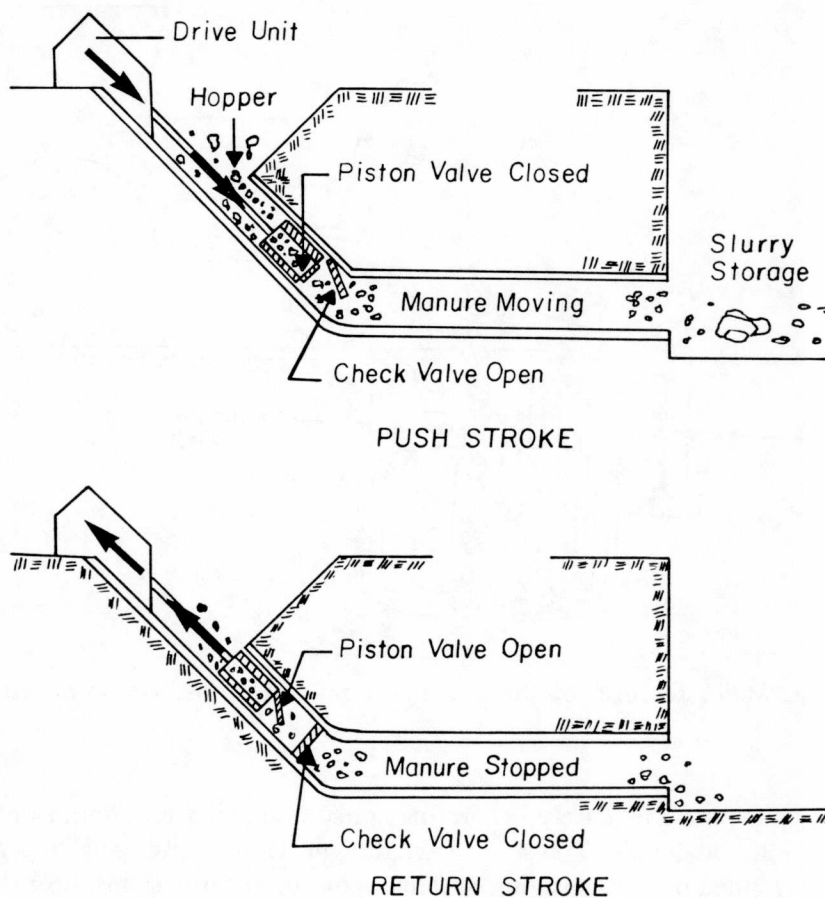

Figure 2. Hollow-piston transfer pump (Midwest Plan Service, 1980).

These pumps are powered by 3.7- to 7.4-kw (5- to 10-hp) electric motors through gear or hydraulic drives. Power requirements depend upon the type of drive, speed, length of pipe, and lift.

Piston pumps have a minimum entry dimension of 20.3 to 30.5 cm (8 to 12 in) and pump through 25.4- to 38.1-cm (10- to 15-in) diameter HDPE pipe to carry manure to the bottom of the storage facilities. Pumping dis-

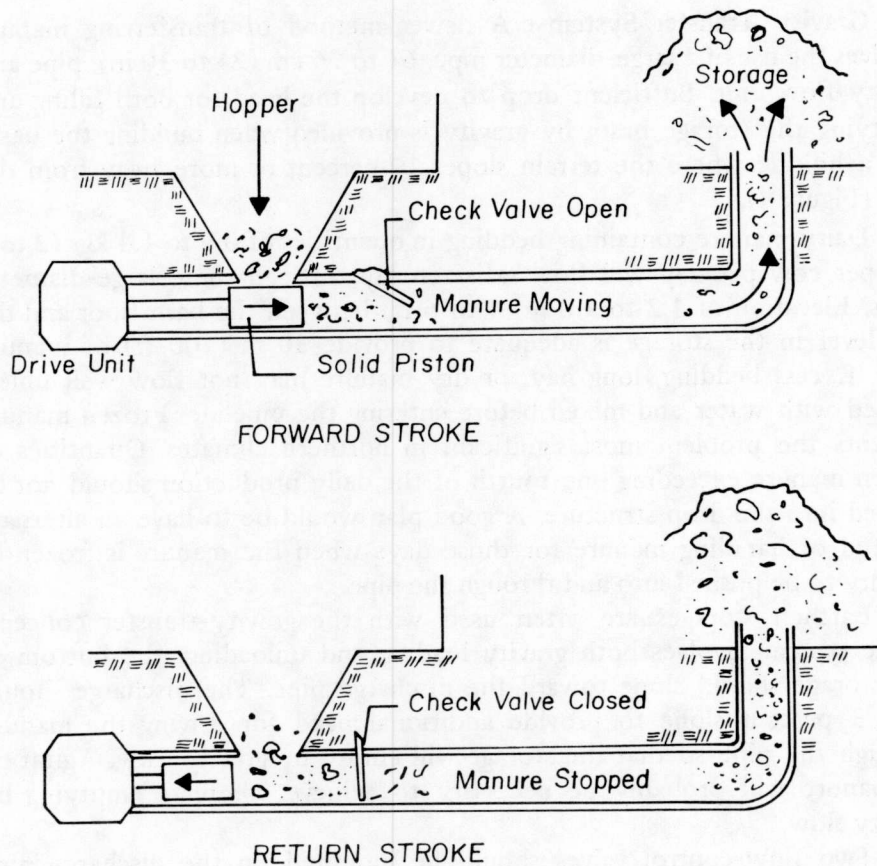

Figure 3. Solid-piston transfer pump (Midwest Plan Service, 1980).

tances range up to 76 m (250 ft). These pumps are installed below the floor level of the barn so that manure can be scraped or conveyed into a hopper above the piston. A manual shutoff valve should be provided where storage is above the level of the barn floor in case the check valve malfunctions.

Management requirements consist of safety covers or grating around hoppers, occasional pump maintenance, and prevention of foreign material entering and plugging the pump.

Gravity Transfer Systems: A newer method of transferring manure involves the use of a large-diameter pipe, 61 to 76 cm (24 to 30 in), pipe and gravity-flow unit. Sufficient drop to develop the head for both filling and emptying the storage basin by gravity is provided when building the basin into a hillside where the terrain slopes 10 percent or more away from the barn (Figure 4).

Dairy manure containing bedding in quantities of 0.9 to 1.4 kgs (2 to 3 lbs) per cow per day will flow satisfactorily through these large-diameter pipes. Elevation of 1.2 to 1.8 m (4 to 6 ft) between the barn floor and the full level in the storage is adequate to provide 30 m (100 ft) of manure flow. Excess bedding, long hay, or dry manure may not flow well unless diluted with water and mixed before entering the pipeline. Frozen manure presents the problem most significant in northern climates. Quantities of frozen manure exceeding one-fourth of the daily production should not be pushed into the drop structure. A good plan would be to have an alternate method of handling manure for those days when the manure is frozen or too dry to be pushed into and through the pipe.

Earthen storages are often used with the gravity-transfer concept. If the system involves both gravity loading and unloading, the bottom of the storage should slope toward the discharge pipe. The discharge should have 3 percent slope to provide additional head for driving the manure through the pipe so that the storage will empty by gravity flow. Agitation of manure will probably be necessary to achieve complete emptying by gravity flow.

Two flow-control valves should be mounted on the discharge pipe (Figure 4). One is typically a manually activated valve used as a safety valve, and the other is hydraulically operated for ease in opening and closing the valve while loading a manure spreader.

Liquid-Storage Systems

Earthen Storage Basins: Earthen storage basins are designed and constructed to prevent ground and surface water contamination while providing long-term manure storage near the barn for a low to moderate investment. These basins for cattle manure produce relatively little odor during the

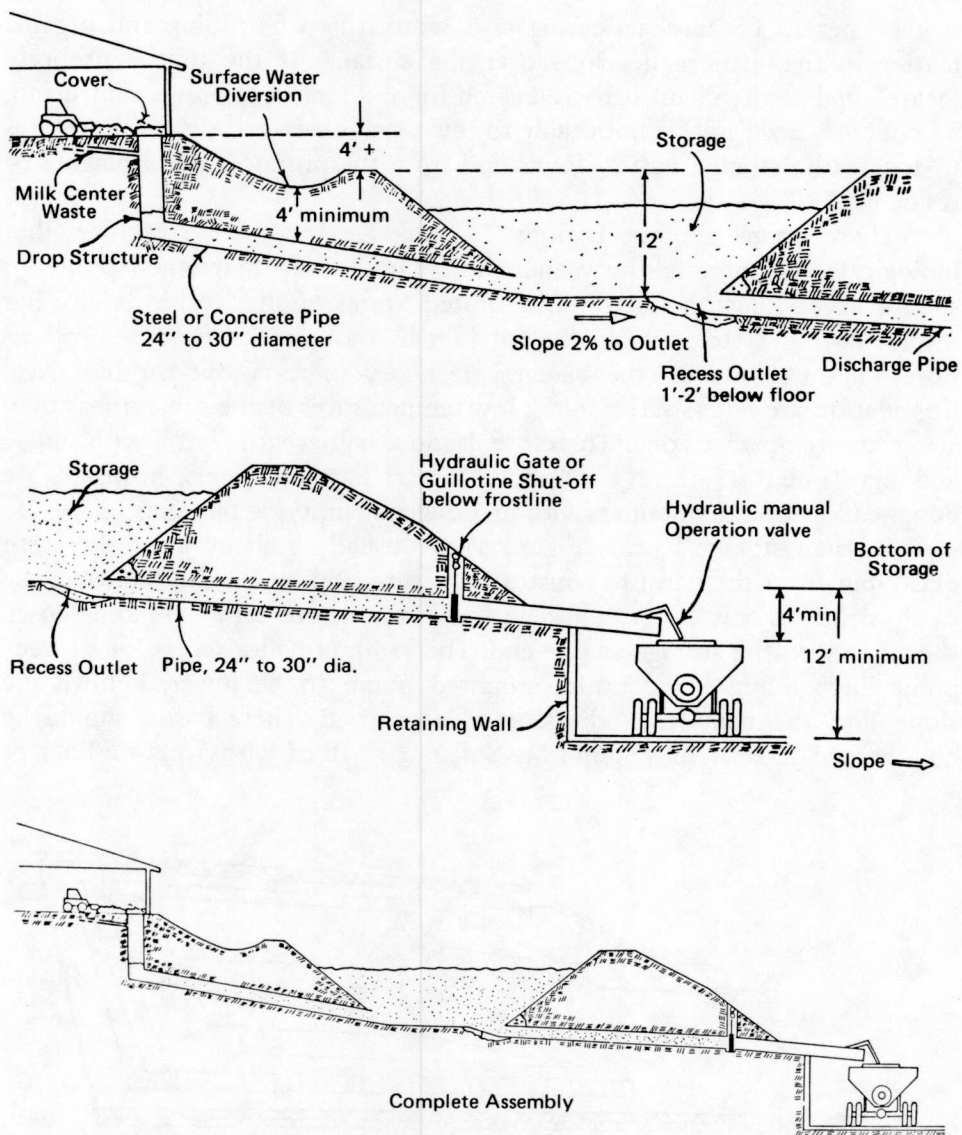

Figure 4. Gravity flow manure transfer, storage, and load-out system (Guest, 1980).

storage period because a floating crust consisting of bedding and organic matter in the manure develops over the surface. If the unit is properly located and earthen banks are well cared for and fenced to prevent intrusion, its contents need not be noticeable to the casual observer. A good practice is to locate the storage basins downwind from the producer's and neighbors' residences.

These basins are not lagoons. Lagoons are treatment structures that biologically decompose the manure into liquid and, if designed properly, should never fill with sludge. The United States Public Health Service has several lagoon systems in Alaska for human waste at least as far north as Fort Yukon. However, the bacteria necessary to carry out the biological degradation are not as active in the low temperatures of the subarctic as they are in the temperate zone. Therefore, lagoons will eventually fill with sludge and may pollute surface and ground water. Earthen basins, however, are designed as storage containers with predesigned emptying facilities.

Earthen storage basins (Figure 5) are usually built by using the earth excavated from the basin to construct the surrounding dikes. Other than the earthwork, the only other consideration is a concrete ramp extending down the slope into the storage at one end. This ramp provides access for a three-point hitch-mounted or trailer-mounted pump to be lowered down the slope into the manure as the storage is emptied. These basins should be constructed in relatively nonporous soils, or be lined with a plastic liner or

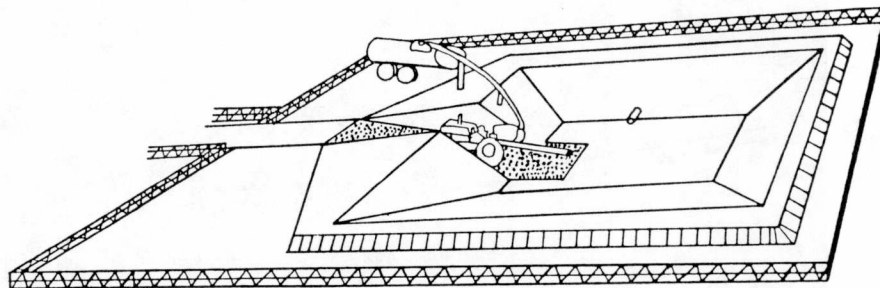

Figure 5. A typical outside, earthen-basin, liquid-manure storage with proper chained-link fence (Midwest Plan Service, 1980).

layer of clay (e.g., driller's mud) to prevent potential groundwater contamination where a basin is to be constructed in porous soils.

Manure can be added to the storage basin from above using liquid-manure pumps, extensions on gutter cleaners, or tractor scrapers. Manure can also be pumped into the bottom through buried pipelines. This method provides for more even distribution of manure solids and reduces fly and odor problems because of the floating crust that normally develops. Adding manure from the top often results in a greater accumulation of settled solids below the inlet, particularly during freezing weather.

Manure generally is transferred from the pump or pneumatic conveyance tank through 30.5-cm (12-in) pipes. The manure enters along one side at the bottom of the storage basin or the pipe is extended toward the center where the manure is disposed of at the bottom of the basin. Both designs work well, but the pipe outlet must be well covered before the event of freezing weather.

Earthen basins should be as deep as possible, minimizing surface area so that the floating crust forms readily. This results in less crust area that will break up and be resuspended with the liquids when it is time to agitate the basin contents in order to remove the manure for land application. On most soils, the inside banks are sloped 2:1 (horizontal to vertical). Inside side slopes of 3:1 have been used, however, this configuration results in a larger surface area requiring more land, catching more rainwater, and developing a larger crust to agitate at pump-out time. The width of the embankment surrounding the basin should be wide enough to mow and to provide access for agitation equipment along one side and one end. Outer side slopes should be not steeper than 3:1, with 4:1 preferred for ease of mowing and maintenance. The concrete ramps into the storage should have a slope no steeper than 7:1 with 10:1 or flatter recommended if the ramp is used for anything other than lowering the tractor and agitation pump. A flat, elevated area where a tractor and tankwagon can be conveniently parked for filling should be provided near the ramp. Safety features should include at least one "danger-area" sign posted on each side of the fence surrounding the basin indicating the contents.

Liquids and manure solids in earthen basins generally are agitated prior to land application with a three-point hitch or trailer-mounted, high-capac-

ity manure pump with the pump mounted at the end of a long boom (Figure 6). The pump can be lowered down an embankment or ramp placing the pump intake just beneath the surface or somewhat deeper. For agitation, the discharge from the pump is directed up and over the top of the surface, landing 18 to 21 m (60 to 70 ft) from the pump. This action breaks the surface crust and develops circular patterns that float chunks of crust toward the pump. These pumps have a chopper and/or rotating auger section at their inlets that further breaks the crust and draws the solids into the pump for thorough mixing with the liquid.

Some earthen basins have a vertical wall or a dike extending out over the surface so that a vertical-shaft, liquid-manure pump can be used for agitation (Figure 7). These pumps, located at the bottom of the vertical shaft well underneath the surface, discharge beneath the surface for agita-

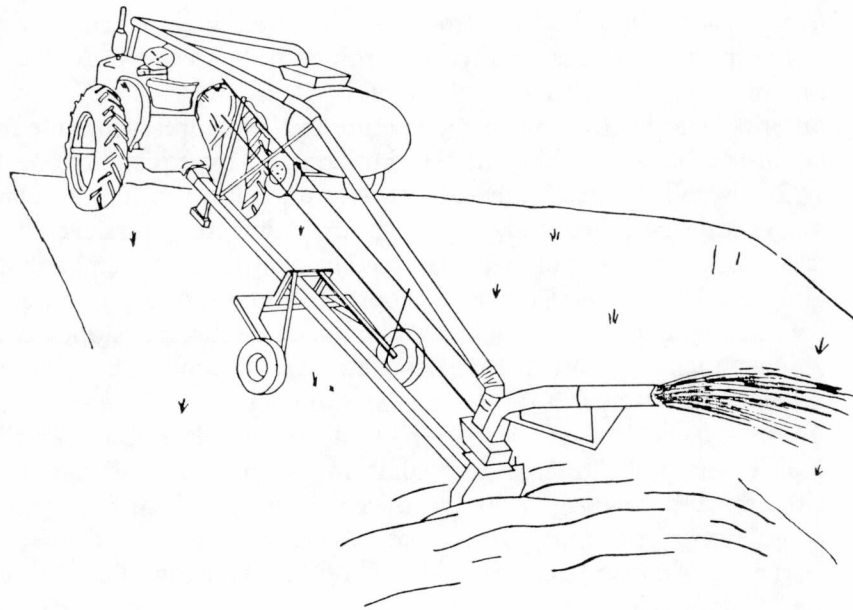

Figure 6. Open-pit pump provides convenience and fastest agitation or pumping from earthen basins.

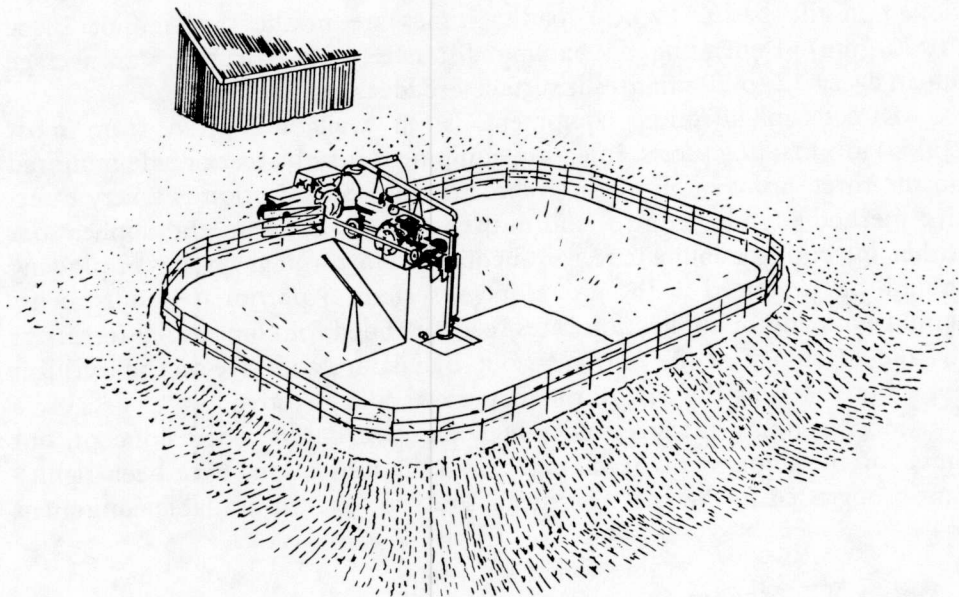

Figure 7. Earthen basin with pumping dock that allows a vertical-shaft manure pump to agitate and pump the liquid material into the tankwagon.

tion. While these pumps can agitate small basins, they are unable to move pieces of crust to and through the pump and, therefore, are not as effective as the boom-type pump for breaking up a hard crust.

Propeller-type agitators are also available on booms to be mounted on three-point hitches which can be lowered over an earthen embankment for agitation. These pumps are newer to the market than the above types, and have the capacity to move large volumes of manure with lower power input.

Land application from outdoor liquid storage is accomplished by conventional hauling or irrigation. With a rapid increase in the size of livestock facilities, operators with confined animals will have problems handling their liquid manure through the conventional hauling method and will have to irrigate.

The conventional hauling method is accomplished with liquid-manure tankwagons loaded with agitation pumps or paddle-type conveyors posi-

tioned in the basin. Typical loading times are in the range of 63 L/sec (1000 gpm). Depending on hauling distance, most dairymen can average a load every 12 to 20 minutes if surface broadcasting.

Direct soil-injection equipment is an available option from most tankwagon manufacturers. Injection equipment may be rear or side mounted on the three-point hitch of the tractor (Figure 8). Injection is a very effective method of odor control and nutrient conservation in land application. Either injection or immediate soil incorporation through discing or plowing should be practiced with any storage system. Appropriate adjustments should be made in application rates recommended for commercial fertilizers to take advantage of the nutrient value of manure and save on the fertilizer bill, thus offsetting the cost of the manure-handling system.

Moving liquid manure under high pressure is not a new concept, but much of the equipment developments and modifications have been significantly upgraded in the past few years. Prior to this, the available equipment



Figure 8. Side-mounted, adjustable, spring-loaded knives inject manure into the soil from the tankwagon.

was not effective if the manure contained such foreign objects as straw, hay, and string and a solids content of more than 5 percent.

Chopper pumps and other equipment have been improved to the point that many operators are pumping waste rather than hauling it. Today, several high-pressure, centrifugal, chopper pumps are on the market which will handle waste with 10 percent solids; lift waste from storage pits 3.0 to 4.6 m (10 to 15 ft); and chop straw, weeds, hair, and other nonanimal waste that are in the manure-storage area. The suction lines have been adapted to pump from underground pits, earthen pits, or above-ground storage facilities. The choppers are a series of knives or blades which rotate to chop the solids in the manure into particles of less than 5.0-cm (1.25-in) in diameter so that they can pass through the pumps. The chopped manure can be pressured through nozzles as small as 1.27 to 1.90 cm (0.5 to 0.75 in) in diameter. Most pumps that produce up to 11.2 kg/cm² (160 psi) at rates of 31.5 to 37.8 L/sec (500 to 600 gpm) with manure at 7 to 8 percent solids content can pump as far as 2414 m (1.5 miles) and distribute through irrigation equipment using 15.2-cm (6-in) diameter pipe.

Aluminum pipe, 15.2 cm (6 in) in diameter and 9.1 m (30 ft) long, is used in most operations to allow layout and removal in a very reasonable amount of time. The coupler should be a type that can be unhooked only by the operator and will not come unhooked accidentally, especially during start up. Alterations of the standard coupler used to connect two pipes for irrigation have been made. PVC pipe is being installed underground in large operations and where aluminum pipe will cause a traffic problem around the farmyard. Flexible hoses also are being used by large operators or in custom pumping operations. Pipe up to 15.2 cm (6 in) in diameter is available on a large reel for transporting.

Large irrigation guns are being redesigned with an outside drive mechanism to turn them. This has allowed the gun to operate in a partial circle at lower pressure and without stalling, thereby eliminating constant attention by the operator and uneven spreading of manure. The traveling gun (Figure 9) has been the most widely used irrigation system. The most common size, utilizing 10.1 to 11.4 cm (4 to 4.5 in) irrigation hose and flow rates of 31.5 to 37.8 L/sec (500 to 600 gpm), produces an application

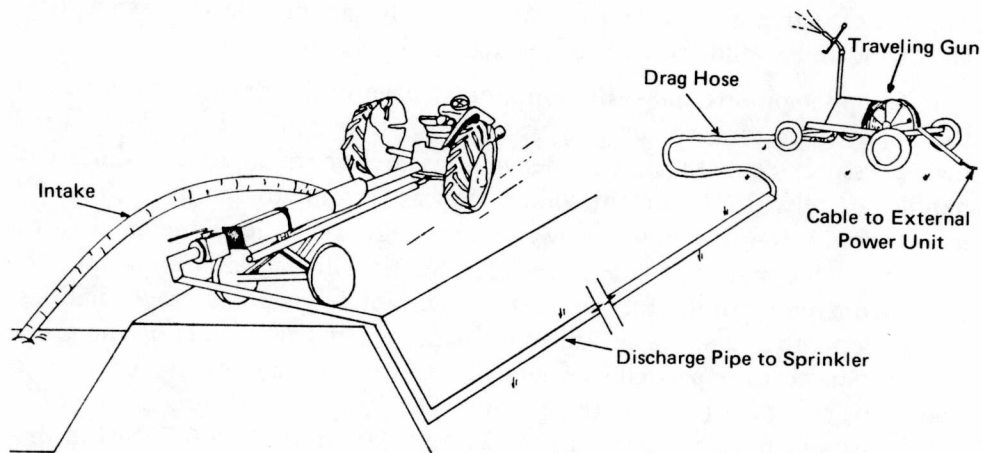

Figure 9. The traveling gun-irrigation system consists of an open-pit manure pump, aluminum pipe, flexible pipe, and the traveling nozzle.

rate of greater than 6308 L/ha (4000 gal/acre). This system allows flexibility, as well as multiple ownership, which is becoming increasingly popular.

Center-pivot irrigation equipment can also be adapted to use large nozzles to handle liquid manure. The small amount of manpower required, the ability to operate in very wet conditions or on frozen soil, and its flexibility have made the irrigation method very acceptable. Another important factor to consider is that the same equipment used for irrigating with liquid manure can also be used for irrigating with water. Two disadvantages associated with the irrigation method, however, are nutrient loss and odors which might be a problem in highly populated urban areas where dairy operations frequently exist.

A remedy to the disadvantages of the irrigation method is the concept of injection through a trailing hose as developed by the city of Chicago, Illinois. This method of handling livestock waste has only recently come into common use. It became even more popular in 1982 when the two-hose method was developed and proved to be a workable method as shown in Figure 10. Attaching a manifold system to a chisel plow or soil saver has also

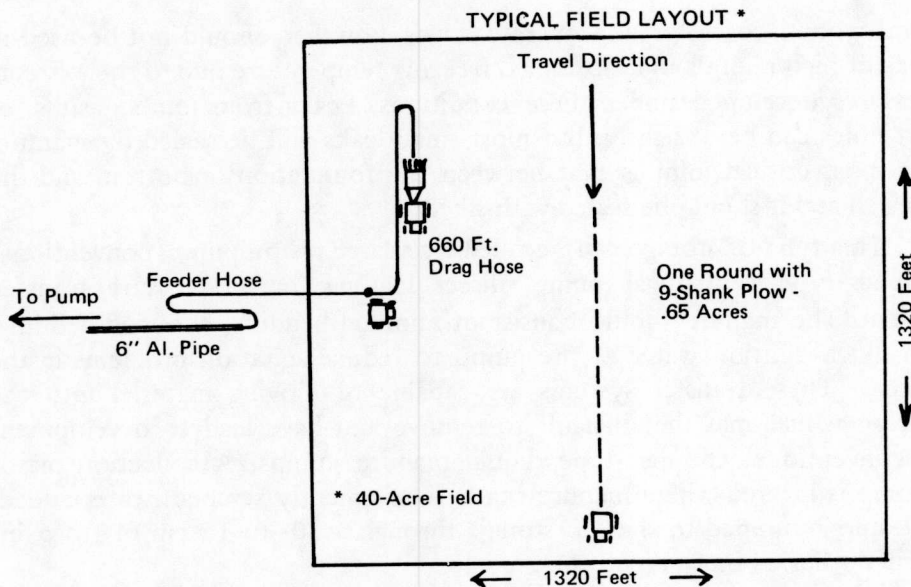

Figure 10. The two-hose method consists of a feeder hose coupled to the drag hose which is in turn coupled to the spring-loaded injector shanks. The injection system is attached to the tractor which pulls the drag hose as manure is pumped from the storage facility (Huffman, 1982).

been introduced in this system to accomplish both tillage and manure injection in one trip, thus minimizing soil compaction.

Above-Ground, Liquid-Manure Storages: Above-ground circular tanks for manure storage are short, wide tanks resembling feed-storage silos. They are expensive compared to earthen basins, but offer versatility in installation. In areas with a high water table, extremely permeable soils on fissured rock, space constraints, or aesthetically unacceptable location for earthen basins, above-ground tanks are a good alternative to below-ground storage.

Construction systems and materials which, if properly designed and erected, make suitable silo storages include concrete staves, reinforced monolithic concrete, lap-joint coated steel, butt-joint coated steel, and

spiral-wound coated steel. Concrete staves, however, should not be used in areas of high rainfall and substained freezing temperature due to the extreme pressures developed under these conditions. Leaks from joints, seams, or bolt holes can be unsightly, but most small leaks will be sealed by manure. The most critical joint is that between the foundation or bottom and the sidewall and it should be sealed with silicon.

This type of storage can be filled by a large piston pump, conventional chopper-type centrifugal pump, direct loading, or air-pressure transfer system. The manure should consist of minimal bedding, chopped bedding, and extra dilution water at the pump to reduce agitation problems in the system. These transfer systems are capable of moving material into the storage which may be difficult to remove and have lead to development of conventional chopper-type, liquid-manure pumps. A collection pit or a sump is located where manure can be conveniently scraped, water added, and slurry pumped to the silo storage through a 10- to 15-cm (4- to 6-in) diameter buried pipe (Figure 11).

The most common method for agitating above-ground storages is with a centrifugal pump mounted in the storage foundation and connected via a large slide valve to an inlet at the base of the silo storage. The tractor power takeoff (PTO) pump achieves agitation by discharging over the top of the storage. A valve on the discharge pipe can be opened to allow the pump to fill the tankwagons or irrigation lines when sufficient agitation has been achieved by this recirculation.

Agitation can be a problem if the storage unit becomes too full or if too much long bedding material has accumulated. If large amounts of sand or ground limestone are allowed in the storage, the settled material will be impossible to pump. Sand should never be used as bedding in free stalls with a liquid manure system, particularly where above-ground storage is employed, unless provisions are made for entry of solid-liquid separation equipment for removal of solids prior to the transfer of liquids to silo storage.

Above-ground storages work well with confinement barns, but they are difficult to use with open lots because of variations in the consistency of manure. Frozen manure cannot be put through the loading pumps. Dry manure requires the addition of water for resuspension and loading purposes.

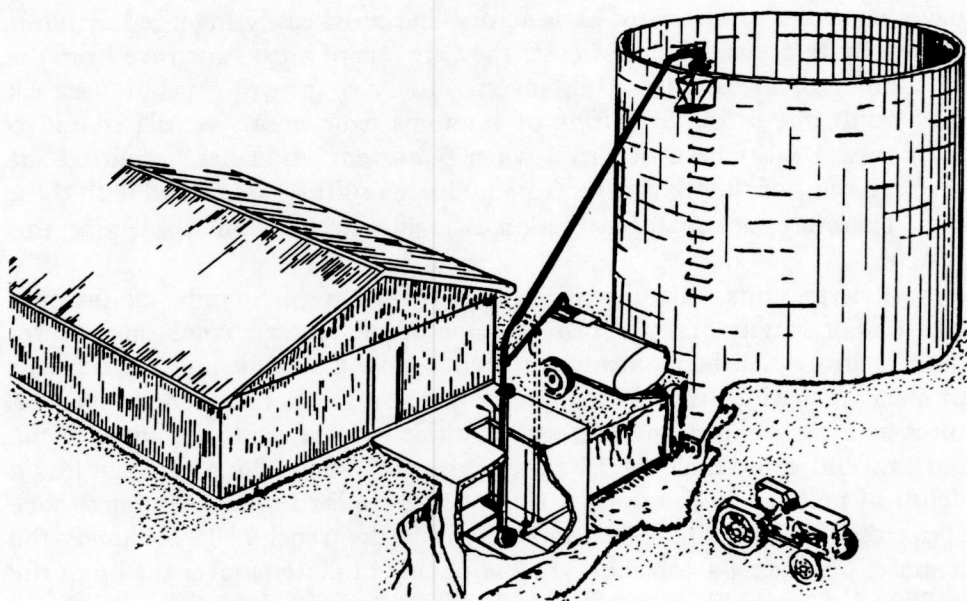

Figure 11. Above-ground, liquid-manure, storage system setup in typical dairy operation (Alberta Environment Agriculture, 1982).

In addition, above-ground storage is too expensive to be used for lot runoff water, which must be handled separately.

Management of above-ground storage requires careful attention. Material pumped into the storage must be in a form (moisture content and particle size) that can be agitated and pumped. Excess water should be kept out. Good convenient access to the storage should be maintained for unloading. Ladders should not be left around to allow unauthorized access to the top of the storage. Agitation pumps, pipes, and valves should be drained during cold weather according to the manufacturer's instructions.

Concrete Pits: Concrete pits have been used for storage of manure either under barns or outdoors, separated from the barn. With this system, manure may be scraped into storage using a tractor or mechanical scraper, or alley floors may be slatted to provide direct transfer into the pit. These pits

have been one of the most satisfactory and most easily managed manure-storage systems available, however, they are one of most expensive from the standpoint of initial cost. Also, adverse effects to growth gains in livestock may result due to the formation of ammonia from poorly ventilated under-barn pits. Deaths have occurred when poor ventilation has permitted the accumulation of the toxic gases (e.g., hydrogen sulfide) associated with these pits. Therefore, adequate ventilation is highly stressed when selecting this system.

Concrete pits have been associated with piston-pump, air-pressure transfer, or gravity transfer systems. One of the systems common in European comfort-stall barns involves a gravity-flow trench behind the tie stalls or stanchions which transfer manure from below grates to concrete pits. Features of these trenches include perfectly flat bottoms and a bulkhead at the outflow end approximately 15 cm (6 in) high which holds a constant liquid depth of material in the trench. The manure tends to form a sloping surface above the bulkhead. Biological activity within the trench helps to liquefy the manure, producing a constant, gradual oozing of material over the lip of the bulkhead. Gravity-flow systems could be used under slatted floor alleys in free-stall barns. Milkhouse wastewater contains disinfectants which are detrimental to biological activity and should not be added to the trenches.

SEMISOLID-MANURE SYSTEMS

Drained Storage

Waste from dairy cattle can be stored and hauled as a solid or semisolid by using conventional equipment found on most farms where calf pens, maternity pens, and young-stock housing are bedded. The hauling schedule from a semisolid storage facility is flexible with units developed for almost any period of storage, from a few days up to several months. One can haul a few loads of manure without planning ahead to agitate the storage facility as is required with liquid manure, and less total material must be hauled from storage since no water is added.

If rainwater is drained from an uncovered storage, manure, because it has the characteristics of a solid, can be handled with loaders and endgate or flail-type spreaders. Such a manure-storage facility requires a structure that will allow rainwater to drain from the storage regardless of the level of manure present. A picket-type structure with continuous vertical slits, about 1.9 cm (0.75 in) wide between standing planks or pickets can retain manure solids while allowing liquid to drain. Manure may be conveyed to the storage with a stacker, a piston pump, or a tractor push-off ramp.

All excess water must be kept out of the manure storage. A picket dam only provides a method for removal of rainwater that has fallen on the storage; it does not lower the water content of the manure. Picket dams may be used in earthen-walled storages (Figure 12). In an earthen-walled storage basin loaded with a stacker, the manure surface is highest beneath the stacker and slopes toward the surrounding earthen walls. The interface between the manure and the earthen dike tends to form a channel for the removal of water. When a drainage structure is properly located, water moves off the crusted surface of the manure, around the edge along the channel formed between the manure and earthen bank, through the vertical slits of the structure, and through an opening provided to allow liquids to drain away.

The concrete load-out ramp should have a slope no steeper than 10:1 and should be at least 12.2 m (40 ft) wide to allow for parking a

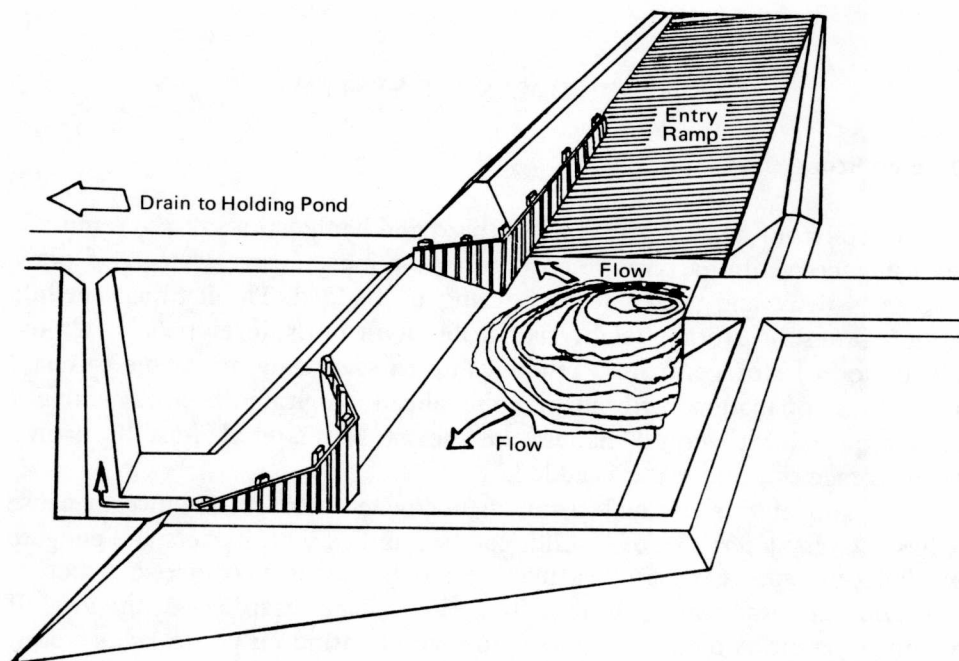

Figure 12. A picket-drained storage system which is loaded along the middle of a long side (Louden et al., 1980).

spreader along one side for loading. A roughened ramp will improve traction, and groves angled across the ramp will provide microchannels to guide rainwater toward the pickets. The level of the ramp at the entry point can be 0.3 to 0.5 m (1.0 to 1.6 ft) below the top of the surrounding walls. The floor of the storage should be a flat, concrete slab.

Drainage water from the manure storage is highly polluted and must be managed so that it does not enter public waters, pollute groundwater, or leave one's own property. Drainage from open lots should be directed to a runoff pond or to a wastewater pond used for milking center wastewater. Another possibility would be to direct it to a grassed area for infiltration into the soil.

Certain management practices are necessary to ensure that a semisolid-handling system will work well. Dry materials such as bedding and long-stem hay must go into the storage with the manure to improve handling characteristics. Where sand is used as bedding in free stalls, this system will not work well. If a semisolid-storage facility is designed for long-term storage, at least one large spreader should be available for hauling; two or three can make the job go much faster. When the storage is cleaned, it is a good idea to clean manure from sloping earthen walls by back-scraping with a bucket loader. This removes the manure seal and provides further removal of liquid through seepage into the walls as the storage fills again. The layer of fine solids accumulated behind the pickets should be removed when the storage is emptied. Any solids forced into the vertical slits between the pickets while loading should also be removed.

One should haul this material during periods when excessive odor problems are not created for neighbors. The best days are those with strong winds which will carry odors directly from storage or field application sites away from neighboring homes. Also humid conditions with little air movement should be avoided when transferring and applying manure solids to field sites.

Above-Ground, Roofed Storage

The concept of above-ground roofed storage (Figure 13) has been developed in the northeast part of the United States during the last few years. The concept involves a storage facility constructed with a concrete floor at or less than 1 m (3 ft) below existing grade. Typically, these storages have walls about 3 m (10 ft) high made of post and plank construction or reinforced concrete, with earthen backfill against the side walls to provide some lateral support needed to withstand fluid manure pressure from within.

Ventilation space is provided between the top of the walls and the trussed-roof construction. Storages of this type usually are bottom loaded using a large-diameter piston pump. This concept was developed initially for comfort-stall barns where manure containing large amounts of bedding were transferred by a solid-piston, hydraulically operated pump from a

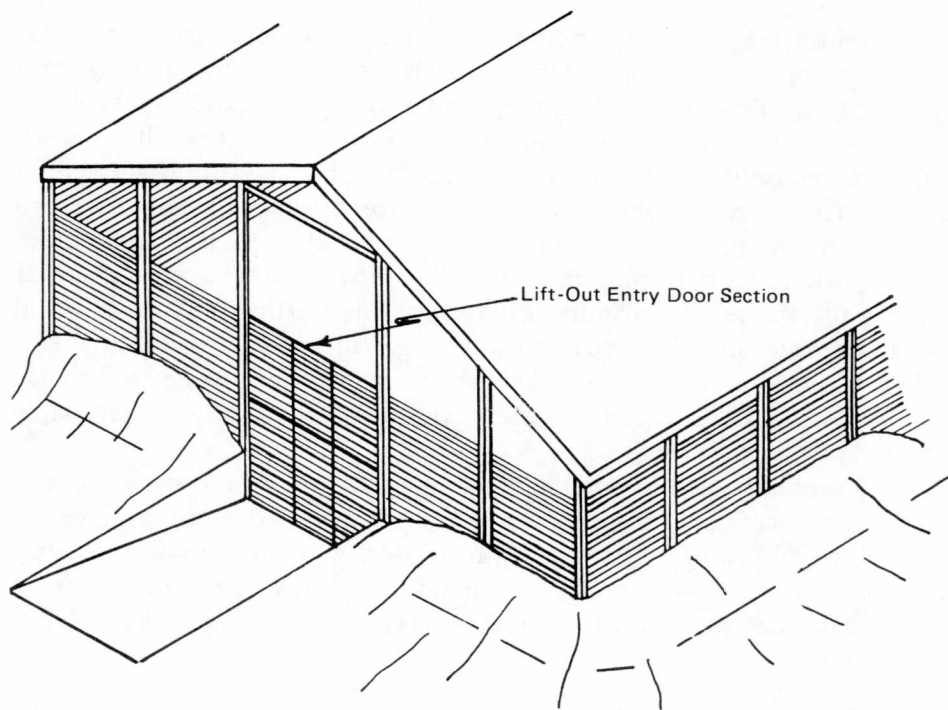

Figure 13. An above-ground roofed structure for semisolid manure storage (Louden et al., 1980).

collection point in the barn to the bottom of storage. Stored manure will crust over and present neither odor or fly-breeding problems.

The roof on this type of storage is provided to keep rainwater from the manure in order to keep the contents as dry and solid as possible. Translucent panels can be used on a south slope of the roof to permit possible further drying by the sun. However, once manure is crusted, it is questionable whether very much drying takes place.

Unloading is typically accomplished by raising a sectioned door made of reinforced planks in one end of the storage. As the uppermost section is raised, manure will begin to flow or slump over the wall onto the sloping concrete pad just outside the storage where it is loaded with a front-end

loader into a conventional spreader. Door sections are removed, in turn, using a hoist supported from a beam above the doorway.

New equipment is being developed and is just starting to reach the market specifically for this semiliquid or semisolid form of manure. In the future, some sort of auger loading system and deep box spreader will be used for manure from free-stall barns which is stored in either above-ground or drained structures of this type.

CONCLUSIONS

Many different systems are now being used on dairy farms to handle and store manure. In general, these systems improve upon the daily-haul system from a labor and machinery efficiency standpoint. The daily-haul method has little upfront cost, and labor and machinery are spread over the entire year. However, this method has three primary disadvantages for its use in Alaska:

1. Hauling manure for herds with more than 50 head requires a great deal of labor.
2. Runoff effluent associated with manure application on frozen ground (usually present about 5 months in Alaska) is above the state's maximum loads (e.g., biochemical oxygen demand, suspended solids, total coliform, fecal coliform, etc.).
3. When workable waste-management facilities are lacking, the cost of renovations to include them are usually as high as new construction.

By storing manure, however, it is possible to do a much better job of conserving nutrients, particularly nitrogen, thus realizing some benefits from the investment in storage. However, the investment required for some of these systems is high and must be considered carefully. Conserved nitrogen can only help pay for the manure-handling system if the dairyman actually buys less commercial fertilizer than he would without the system.

Currently, no one best system exists to collect, transfer, store, and dispose of manure from dairy operations. Managerial, environmental, and economical factors all must be considered in selecting a manure-handling system for the modern dairy. There is a need for continued improvements, research, and innovations in this area.

BIBLIOGRAPHY

- Alberta Environment Agriculture. 1982. Code of Practice. Confinement livestock facilities waste management. Edmonton, Alberta.
- Graves, R. E. 1977. Moving manure with air pressure. AEN-31. Agricultural Engineering Department, University of Wisconsin, Madison, WI.
- Guest, R. W. 1980. Gravity manure handling. Northeast Dairy Practices Council. NDPC 27.10.
- Huffman, Thomas R. 1982. High pressure animal waste pumping. ASAE Paper No. 82-4579. American Society of Agricultural Engineers, St. Joseph, MI.
- London, T. L., T. R. Smith, and J. A. Speicher. 1980. An overview of recent developments in dairy handling systems. American Dairy Science Association 75th Annual Meeting. Cooperative Extension Service, Michigan State University.
- Midwest Plan Service. 1980. Livestock Waste Facilities Handbook. MWPS-18. Iowa State University.