

LPM-00441

How to Grow Your Own Holiday Turkey

Many Alaskans find that growing a few turkeys is both rewarding and educational. Several varieties of turkey yield excellent meat for home consumption when they are properly fed and managed.

Young turkeys are called poults and are classified by varieties, not breeds, because the North American Wild Turkey is the direct ancestor of all domestic turkeys. Some breeders claim that the Beltsville Small White is divergent enough to be considered a distinct species, but it is treated as a variety in this publication.

There are seven turkey varieties, of which only the following three are useful for meat production.

1. The **Broad-Breasted Bronze (BBB)** is the largest variety of turkey. The average adult body weight is 35 pounds for toms and 19 pounds for hens. Some strains weigh as much as 50 pounds. Turkeys of this variety are best when slaughtered between 22 and 24 weeks of age.
2. The **Broad-Breasted Large White (BBLW)** is the most popular turkey variety in Alaska. The average adult body weight is 32 pounds for toms and 18 pounds for hens. The hens grow rapidly in the early stages of development, so they are often slaughtered at 12 weeks to produce fryer-roasters of 7 to 8 pounds. Males are usually slaughtered at about 24 weeks of age.
3. The average weight of the **Beltsville Small White (BSW)** adult is 20 pounds for toms and 11 pounds for hens. They are best slaughtered at 16 weeks of age to produce dressed-out hens of 6 pounds and toms of 10 pounds.



Select a variety based on the amount of time that you want to spend to raise an adult turkey and the weight of the bird that you want to produce. It's best to grow only one variety, because when sexes of different varieties are mixed in confined areas, hens of smaller varieties will be crowded away from feeders and waterers and generally stressed by toms of larger varieties.

It is recommended that you purchase at least four to six poults. Even if you lose a young poult (which is highly probable), you will still have home-grown turkeys for Thanksgiving, Christmas and other special events. April is the best time to buy poults to produce adult turkeys for the holiday season and to take full advantage of favorable weather and range forages.

You can order poults of a specific variety and sex through a local feed store owner, or you can order poults directly from a poultry supply house in the Lower 48.

Housing and Equipment for Brooding Poults

A small building with a floor or a partitioned-off corner of a building are adequate areas for brooding poults. Many Alaskans brood poults in their home, which is acceptable if the brooder is cleaned daily; it is especially beneficial to poults in the spring when outdoor temperatures are cold. Many poults are successfully brooded in cardboard boxes.

The brooding temperature for day-old poults is 90°F. At six weeks of age, poults require a temperature of 65° to 70°F. A good way to supply heat is to suspend a light bulb over the brooder. To decide what size bulb to use and how high to hang it above the brooder, observe how the young poults react to bulbs of various sizes placed at various distances from them. If poults huddle in a tight cluster under a bulb, they are too cold. If they huddle in corners of the brooder away from the light, they are too hot. If they move freely throughout the brooder area, that indicates that the temperature is appropriate for them.

Place newspaper on the floor of the brooder and change it every day to reduce odor and moisture problems.

Housing and Equipment for Growing and Finishing Turkeys

When poults are six weeks of age, they may be removed from the brooder and placed in an outdoor house and pen. If temperatures are below 60°F, supplemental heat will be needed until temperatures rise or until the birds are four to five weeks old.

It is not necessary that housing be elaborate or expensive, but it should provide protection from rain, wind and predators. Turkeys should not be housed with chickens as it increases the risk of disease. Since chickens are

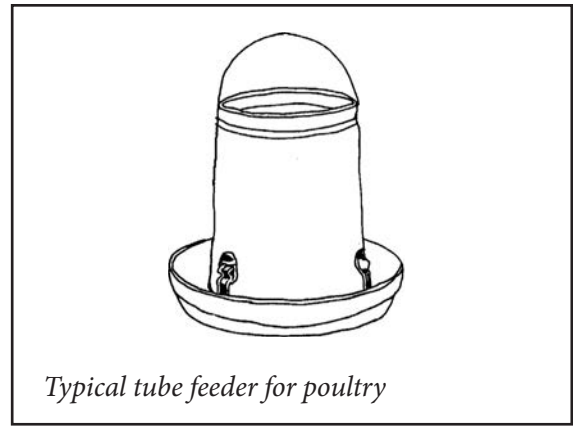

Typical tube feeder for poultry

smaller than turkeys, they cannot successfully compete for food and water. Housing should provide adequate space for birds to grow. A mature turkey requires 5.5 square feet of floor space, so six turkeys would need 33 square feet of floor space.

Before placing poults in a house that was previously occupied by other poultry, thoroughly clean the entire area. Clear out all manure and bedding and remove dust from the walls and ceiling. Then scrub down the entire area with a solution containing 1 ounce of detergent and 3 ounces of household bleach per gallon of hot water.

If you plan to raise turkeys to maturity indoors, the building should have window area equal to at least 10 percent of the floor size. Ventilation is also important. Plenty of fresh air should be provided without subjecting poults to drafts. Vents for incoming air should be placed on the sides of the building 2 to 3 feet above the floor, and exhaust air vents should be placed near the roof.

A tube-type self-feeder is by far the most convenient and practical type of feeder for producing a few turkeys. It should be suspended from the roof and raised to breast level as the birds grow so that they will not scratch at the container and waste feed. The amount of feed that is saved by placing the feeder at breast level will more than pay for the feeder. Tube-type feeders also save work for producers because they have to be filled only once or twice a week, depending on the number of turkeys that are being fed. A 1-gallon fountain-type waterer is recommended to provide fresh water to turkeys.

For more information on poultry equipment plans for chickens, turkeys, pigeons and rabbits see UAF Cooperative Extension Service publication FSG-00540, *Poultry Equipment Plans*.

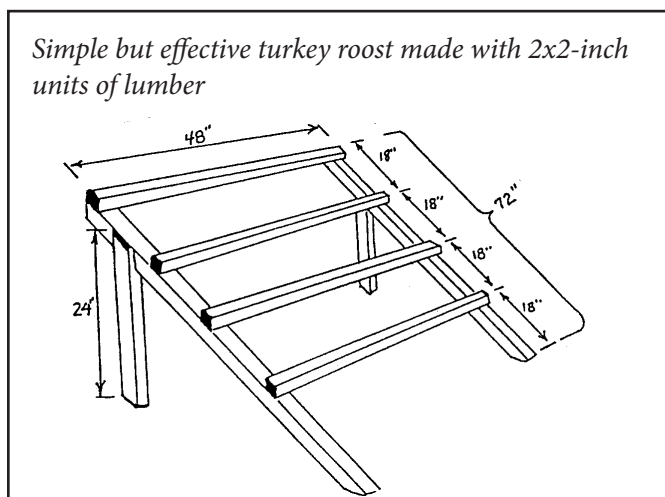

Simple but effective turkey roost made with 2x2-inch units of lumber

Feeding Turkeys

A number of chicken and turkey feeds are available in Alaska. Turkeys that are fed the types of premixed feeds described below usually will reach full growth several weeks sooner than will turkeys that are raised on home-mixed feeds.

1. **Starter feeds** are high in crude protein (26 to 28 percent) and in micronutrient content. They are low in energy in comparison to feeds used for growing and finishing turkeys. Starter feeds are available in either crumble or pellet form.

Poult are almost blind for the first few days after they are born, so if you start with brand-new poults, they may need your help to find feed and water.

Tapping the feeder and waterer will immediately arouse the poults' curiosity and attract them to the tapping sound. Bright marbles have been used successfully in feed and water to prompt poults to eat and drink. As a last resort, their beaks can be manually forced into feed and water.

2. **Growing feeds** contain 20 to 24 percent crude protein and are moderate in energy and micronutrient content. These feeds are designed for growth and flesh development, and they usually come in crumble and pellet forms. Poults are usually started on a grower ration between four and six weeks of age.

3. **Finishing feeds** contain 14 to 16 percent crude protein and are relatively high in energy compared to starter and grower feeds. They are designed to continue the growth of birds and produce some fat to finish and round out the carcass. Finishing feeds usually are available as crumbles or pellets.

The accumulative feed consumption of the three popular varieties of turkey from one week of age until they reach adult size is shown in Table 1.

Other Feeds

1. Add a **vitamin supplement** to water for poults for the first week after they are born to help them ward off colds and other diseases.
2. **Water:** Fresh, clean water should be available 24 hours a day. Turkeys will consume water at a ration of 2½ times the amount of feed they eat per day. Six mature turkeys can drink 1 gallon of water per day.
3. **Grit:** Whether or not grit is essential in a turkey's diet is widely debated, so decisions about its use are left to turkey producers. If turkeys have access to the outdoors, sources of grit are available to them. If you decide to provide grit to turkeys that are confined indoors, begin when poults are five weeks of age on a free-choice basis.

Table 1. Accumulative Feed Consumption of Poults (total pounds of feed consumed to current age)

Age in weeks	Beltsville Small White		Broad-Breasted Bronze and Broad-Breasted Large White Turkeys		Protein Level
	Hens	Toms	Hens	Toms	
					All
1	00.15	00.15	00.18	00.20	Turkey Starter 28%
2	00.45	00.50	00.53	00.58	
3	00.92	1.00	1.10	1.20	
4	1.60	1.90	1.80	2.10	
5	2.20	3.00	3.00	3.40	
6	2.80	4.10	4.10	4.60	
7	3.70	5.70	6.00	6.70	Turkey Grower 20%–24%
8	4.50	7.20	7.90	8.80	
9	5.80	9.00	10.50	12.20	
10	7.00	10.80	13.20	15.60	
12	10.20	15.60	18.20	23.70	
14	14.30	21.60	24.00	32.40	
16	19.40	28.20	32.30	41.40	Turkey Finisher 14%–16%
22	38.30	50.50	58.00	72.50	
26	—	—	78.00	98.00	

4. **Leaves from garden vegetables** such as beets, broccoli, turnips, kale, collards, cauliflower, carrots, cabbage and rutabagas have been fed to turkeys and reduce the amount of commercial feed required.
5. **Potatoes** can also be fed to turkeys, but they should be boiled before feeding.

6. **Young grass and plants** of native and domestic species can be fed as a supplement. Vegetable leaves, grasses and plants should never be fed as a total diet for turkeys.

If you plan to use range grasses extensively or to mix your own feeds using Alaska grown products, contact your local Extension office for advice on balancing rations.

www.uaf.edu/ces or 1-877-520-5211

Stephen Brown, Extension Faculty, Agriculture and Horticulture. Originally prepared by Jerry Purser, former Extension Agriculture Development Agent.



Published by the University of Alaska Fairbanks Cooperative Extension Service in cooperation with the United States Department of Agriculture. The University of Alaska is an AA/EO employer and educational institution and prohibits illegal discrimination against any individual: www.alaska.edu/nondiscrimination.

©2021 University of Alaska Fairbanks.

05-85/IP/03-21

Reviewed March 2021